

## Saunders<sup>®</sup> 2-Way Forged Bodies

[www.cranecpe.com](http://www.cranecpe.com)

The standard 2-way valve body is the basic building block of diaphragm valve technology. CRANE ChemPharma, Saunders<sup>®</sup> 2-way forged bodies are manufactured from wrought 316L/1.4435 stainless steel bar.

The forging process results in a homogeneous surface that is free of defects such as porosity, inclusions, or shrinkage cavities. This defect-free surface is an ideal substrate for the high levels of mechanical and electropolished surfaces demanded by the clean processing industries to maintain sterility and optimize cleaning processes. Saunders<sup>®</sup> forged bodies are manufactured to achieve low ferrite levels of less than 0.5%. This reduces the potential for migration of oxides through a high purity water system.

### Valve body features include:

- 1 Cavity-free and self draining
- 2 Readily incorporated into valve cluster and access valve fabrications
- 3 Materials of construction and surface finish compatible with industry standards system requirements
- 4 Bi-directional flow path
- 5 Full traceability to EN 10204 3.1 and ASME BPE

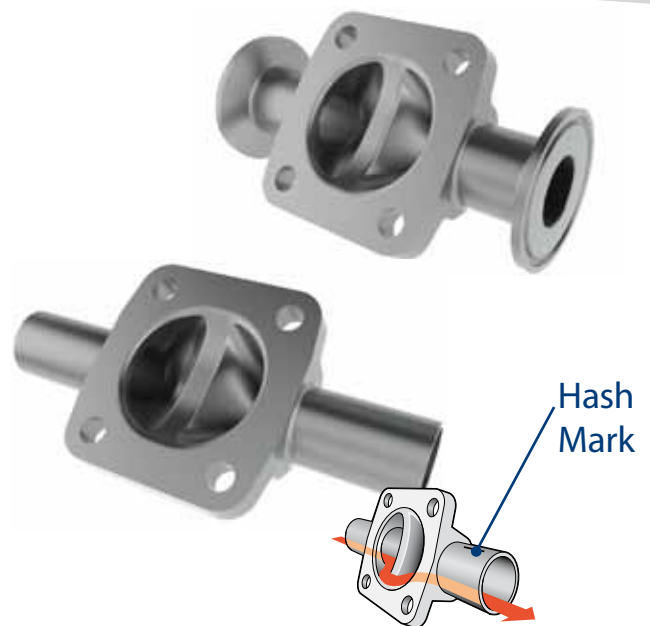

### Forged body features include:

- 1 Hash marks to indicate self drain angle
- 2 Integral weld and hygienic clamp ends
- 3 Controlled sulfur, 0.005% - 0.017 per ASME BPE Standard

## 2-Way Forged Bodies



Saunders® 2-Way Body Forging is produced from 316L bar which meets ASTM A-182, DIN 1.4435 (EN 10222-5) and is compliant with ASME BPE table DT-3 for controlled sulfur (0.005%-0.017%).

All major tube specifications (Tube OD, DIN, and ISO) are machined integrally from the forging to provide maximum integrity. Saunders® 2-way forgings may be installed in vertical or horizontal lines as required with hash marks to indicate optimum drain angle supplied as standard.

In addition, the tube OD forging fully complies with ASME BPE requirements and features integral 38mm (1.5") tangents to permit orbital welding with all available weld heads.

To provide maximum flexibility of configuration, Saunders® DN8 (0.25") forging (Biotek Pure Performance) is available with optional end dimensions. A compact envelope is achieved with 0.25" (DN8) weir and bonnet flange with ends machined integrally in sizes 0.25" (DN8), 0.375" (DN10) and 0.50" (DN15). All major tube standards (Tube OD, DIN, ISO) are available.

Saunders® forged bodies are manufactured to achieve low ferrite levels of less than 0.5%.

## 2-Way Forged Body Dimensions ASME BPE OD

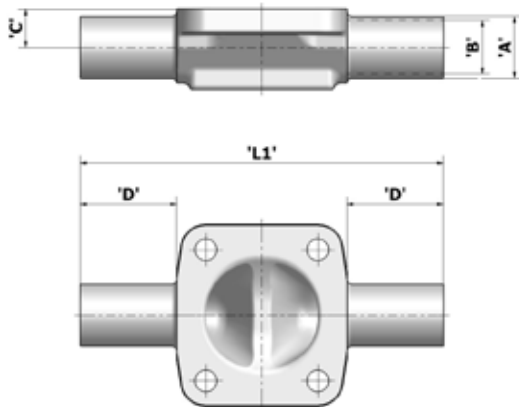

2-Way Forged Body ASME BPE OD Tube Weld End

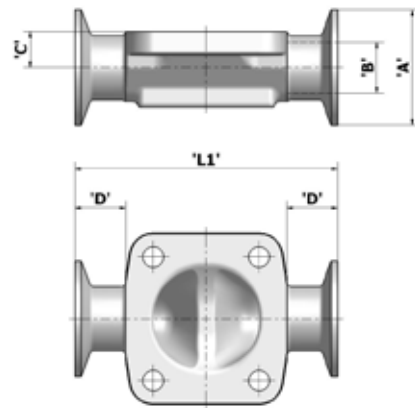

2-Way Forged Body ASME BPE OD Tube Hygienic Clamp

### 2-Way Forged Body ASME BPE OD Tube Weld End

Valve Size		A		B		C		D		L1	
mm	inch	mm	inch	mm	inch	mm	inch	mm	inch	mm	inch
<b>DN8</b>	<b>0.25</b>	6.35	0.25	3.05	0.12	8.6	0.34	21.5	0.85	78.0	3.07
<b>DN8 (DN10 End)</b>	<b>0.25 (0.375 End)</b>	9.53	0.38	6.23	0.25	8.6	0.34	21.5	0.85	78.0	3.07
<b>DN8 (DN15 End)</b>	<b>0.25 (0.5 End)</b>	12.70	0.50	9.40	0.37	8.6	0.34	21.5	0.85	78.0	3.07
<b>DN15</b>	<b>0.5</b>	12.70	0.50	9.40	0.37	9.4	0.37	41.0	1.61	130.0	5.12
<b>DN20</b>	<b>0.75</b>	19.05	0.75	15.75	0.62	13.0	0.51	39.8	1.57	139.7	5.50
<b>DN25</b>	<b>1.00</b>	25.40	1.00	22.10	0.87	15.7	0.62	39.7	1.56	149.4	5.88
<b>DN40</b>	<b>1.5</b>	38.10	1.50	34.80	1.37	22.0	0.87	41.5	1.63	177.8	7.00
<b>DN50</b>	<b>2.0</b>	50.80	2.00	47.50	1.87	28.4	1.12	42.8	1.69	193.5	7.62
<b>DN65</b>	<b>2.5</b>	63.50	2.50	60.20	2.37	40.5	1.59	41.5	1.63	217.0	8.54
<b>DN80</b>	<b>3.0</b>	76.20	3.00	72.90	2.87	48.0	1.89	48.0	1.89	254.0	10.00

All dimensions shown in imperial and metric.  
Web-based drawing number [Web-001](#).

### 2-Way Forged Body ASME BPE OD Tube Hygienic Clamp

Valve Size		A		B		C		D		L1	
mm	inch	mm	inch	mm	inch	mm	inch	mm	inch	mm	inch
<b>DN8</b>	<b>0.25</b>	25.00	0.98	3.05	0.12	8.6	0.34	14.6	0.57	64.3	2.53
<b>DN8 (DN10 End)</b>	<b>0.25 (0.375 End)</b>	25.00	0.98	6.23	0.25	8.6	0.34	14.6	0.57	64.3	2.53
<b>DN8 (DN15 End)</b>	<b>0.25 (0.5 End)</b>	25.00	0.98	9.40	0.37	8.6	0.34	14.6	0.57	64.3	2.53
<b>DN15</b>	<b>0.5</b>	25.00	0.98	9.40	0.37	9.4	0.37	20.7	0.81	88.9	3.50
<b>DN20</b>	<b>0.75</b>	25.00	0.98	15.75	0.62	13.0	0.51	20.8	0.82	101.6	4.00
<b>DN25</b>	<b>1.00</b>	50.40	1.98	22.10	0.87	15.7	0.62	22.0	0.87	114.3	4.50
<b>DN40</b>	<b>1.5</b>	50.40	1.98	34.80	1.37	22.0	0.87	22.5	0.89	139.7	5.50
<b>DN50</b>	<b>2.0</b>	63.90	2.52	47.50	1.87	28.4	1.12	24.6	0.97	158.8	6.25
<b>DN65</b>	<b>2.5</b>	77.40	3.05	60.20	2.37	40.5	1.59	30.6	1.20	195.1	7.68
<b>DN80</b>	<b>3.0</b>	90.90	3.58	72.90	2.87	48.0	1.89	32.8	1.29	223.6	8.80

All dimensions shown in imperial and metric.  
Web-based drawing number [Web-002](#).

## 2-Way Forged Body Dimensions OD Tube Hygienic Clamp

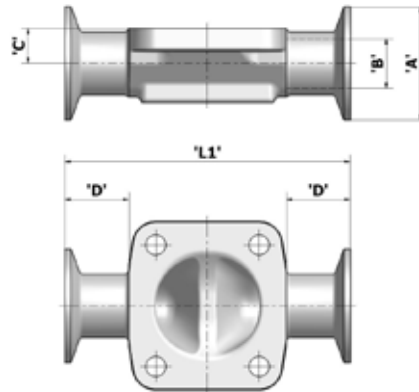

2-Way Forged Body OD Tube Hygienic Clamp (EN558 Series 7 Length)

### 2-Way Forged Body OD Tube Hygienic Clamp (EN558 Series 7 Length)

Valve Size		A		B		C		D		L1	
mm	inch	mm	inch	mm	inch	mm	inch	mm	inch	mm	inch
<b>DN8</b>	<b>0.25</b>	25.00	0.98	3.05	0.12	8.6	0.34	21.5	0.85	78.0	3.07
<b>DN8 (DN10 End)</b>	<b>0.25 (0.375 End)</b>	25.00	0.98	6.23	0.25	8.6	0.34	21.5	0.85	78.0	3.07
<b>DN8 (DN15 End)</b>	<b>0.25 (0.5 End)</b>	25.00	0.98	9.40	0.37	8.6	0.34	21.5	0.85	78.0	3.07
<b>DN15</b>	<b>0.5</b>	25.00	0.98	9.40	0.37	9.4	0.37	30.0	1.18	108.0	4.25
<b>DN20</b>	<b>0.75</b>	25.00	0.98	15.75	0.62	13.0	0.51	28.5	1.12	117.0	4.61
<b>DN25</b>	<b>1.00</b>	50.40	1.98	22.10	0.87	15.7	0.62	28.5	1.12	127.0	5.00
<b>DN40</b>	<b>1.5</b>	50.40	1.98	34.80	1.37	22.0	0.87	32.0	1.26	159.0	6.26
<b>DN50</b>	<b>2.0</b>	63.90	2.52	47.50	1.87	28.4	1.12	41.0	1.61	190.0	7.48
<b>DN65</b>	<b>2.5</b>	77.40	3.05	60.20	2.37	40.5	1.59	41.5	1.63	217.0	8.54
<b>DN80</b>	<b>3.0</b>	90.90	3.58	72.90	2.87	48.0	1.89	48.0	1.89	254.0	10.00

All dimensions shown in imperial and metric.  
Web-based drawing number [Web-049](#).

## 2-Way Forged Body Dimensions DIN Series

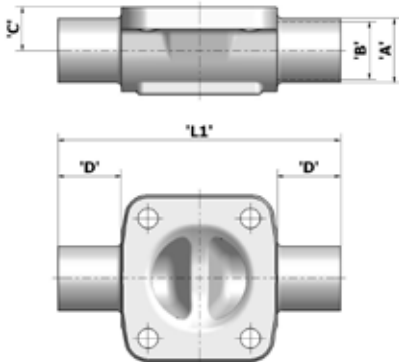

2-Way Forged Body Weld End Dimensions  
DIN11866 Series A/DIN 11850 Series 1 & 2  
DIN 11866 Series B/ISO 1127 Series 1

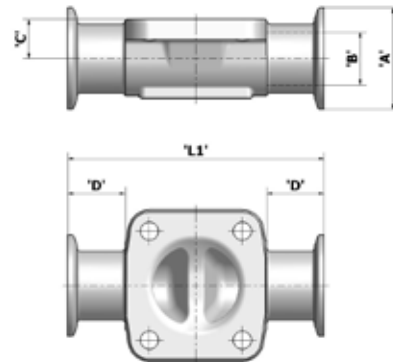

2-Way Forged Body Hygienic Clamp Dimensions  
DIN11866 Series A/DIN 11850 Series 1 & 2  
DIN 11866 Series B/ISO 1127 Series 1

### 2-Way Forged Body Weld End DIN11866 Series A/DIN 11850 Series 1 & 2, DIN 11866 Series B/ISO 1127 Series 1

Valve Size	A		B		C		D		L1	
	DIN	ISO	DIN	ISO	DIN	ISO	DIN	ISO	DIN	ISO
<b>DN8 (DN10 End)</b>	13.00	13.50	10.00	10.30	9.6	9.6	21.5	21.5	78.0	78.0
<b>DN15 (DN10 End)</b>	13.00	17.20	10.00	14.00	13.0	13.0	30.5	30.5	108.0	108.0
<b>DN15</b>	19.00	21.30	16.00	18.10	13.0	13.0	30.5	30.5	108.0	108.0
<b>DN20</b>	23.00	26.90	20.00	23.70	16.0	16.0	28.5	28.5	117.0	117.0
<b>DN25</b>	29.00	33.70	26.00	29.70	19.5	19.5	28.5	28.5	127.0	127.0
<b>DN40 (DN32 End)</b>	35.00	42.40	32.00	38.40	28.0	28.0	31.5	31.5	159.0	159.0
<b>DN40</b>	41.00	48.30	38.00	44.30	28.0	28.0	31.5	31.5	159.0	159.0
<b>DN50</b>	53.00	60.30	50.00	55.10	33.5	33.5	41.0	41.0	190.0	190.0
<b>DN65</b>	70.00	76.10	66.00	70.90	40.5	40.5	41.5	41.5	217.0	217.0
<b>DN80</b>	85.00	88.90	81.00	83.70	48.0	48.0	48.0	48.0	254.0	254.0

All dimensions shown in mm.

Web-based drawing number [Web-091 \(ISO 1127 S1\)](#).

Web-based drawing number [Web-094 \(DIN 11850 S1/S2\)](#).

### 2-Way Forged Body Hygienic Clamp DIN11866 Series A/DIN 11850 Series 1 & 2, DIN 11866 Series B/ISO 1127 Series 1

Valve Size	A		B		C		D		L1	
	DIN	ISO	DIN	ISO	DIN	ISO	DIN	ISO	DIN	ISO
<b>DN8 (DN10 End)</b>	34.00	34.00	10.00	10.30	9.6	9.6	21.5	21.5	78.0	78.0
<b>DN15 (DN10 End)</b>	34.00	34.00	10.00	14.00	13.0	13.0	30.5	30.5	108.0	108.0
<b>DN15</b>	34.00	34.00	16.00	18.10	13.0	13.0	30.5	30.5	108.0	108.0
<b>DN20</b>	34.00	34.00	20.00	23.70	16.0	16.0	28.5	28.5	117.0	117.0
<b>DN25</b>	50.40	50.40	26.00	29.70	19.5	19.5	28.5	28.5	127.0	127.0
<b>DN40 (DN32 End)</b>	63.90	63.90	32.00	38.40	28.0	28.0	31.5	31.5	159.0	159.0
<b>DN40</b>	63.90	63.90	38.00	44.30	28.0	28.0	31.5	31.5	159.0	159.0
<b>DN50</b>	77.40	77.40	50.00	55.10	33.5	33.5	40.9	40.9	190.0	190.0
<b>DN65</b>	90.90	90.90	66.00	70.90	40.5	40.5	42.0	42.0	217.0	217.0
<b>DN80</b>	105.90	105.90	81.00	83.70	48.0	48.0	48.0	48.0	254.0	254.0

All dimensions shown in mm.

Web-based drawing number [Web-092 \(ISO 1127 S1\)](#).

Web-based drawing number [Web-095 \(DIN 11850 S1/S2\)](#).

# Saunders® 2-Way Forged Bodies

## Size Range

¼" through 3" (DN8 through DN80)

## Materials – Body

- 316L ASTM A-479
- DIN 1.4435 (EN 10222-5)
- AL6XN
- Hastelloy®
- Other grades on request

## Materials – Weld Ends Machined Integrally

- 316L ASTM A269/A270, DIN11850
- Controlled Sulfur 0.005%-0.017% ASME BPE

## End Connections

- Tube OD per ASME BPE, BS, ISO 1127, DN11850, SMS
- Hygienic Clamp

## Surface Finish ID

- All ASME BPE finishes
- Saunders®: Satin and Mirror

## Bonnets and Actuators

- Uses standard Saunders® manual bonnets
- Uses standard Saunders® actuators

## Diaphragms

Available with Saunders® Life Science FDA conforming diaphragms

All valve bodies are fully material heat traceable to EN 10204 3.1. Certified Mill Test Reports are provided as standard

Hastelloy® is a registered trademark of Haynes International, Inc.

Please visit our Web-Based Drawing Library at: [www.saundersdrawings.com](http://www.saundersdrawings.com) for current database of drawings in PDF, 2D DWG, and 3D STP formats.

The logo for CRANE, featuring the word "CRANE" in a bold, sans-serif font inside a thin orange rectangular border.

[www.cranecpe.com](http://www.cranecpe.com)

CRANE ChemPharma Flow Solutions, Saunders® • 9860 Johnson Road  
Montgomery, Texas USA 77316 • Tel.: +1 936 588 8360 • Fax: +1 936 588 8302

IMPORTANT: CRANE Co. and its subsidiaries are not responsible for the accuracy, compliance, and legality of material contained in this datasheet offered in print, on the company websites, or via any external links, or third party sites.